



Direct Mount 3-Way Full / Standard Port Ball Valve



Model: HC-3WDM

Rating: 1000 C.W.P.

Design feature:

- 4- Seat design, direct-mount 3 way ball valve.
- Direct-mounting of actuator to valves, low cost and easy automation.
- Integral Twin pattern ISO 5211 mounting pad for double & spring return actuator.
- Self-adjusting stem packing assembly with Belleville spring for temperature fluctuations, vibration, and is secured.
- Thrust washer prevents galling, reduces torque and provides secondary stem seal. Long cycle life, Low uniform torques.
- Bottom Entry Blow-Out Proof Stem design Provides Maximum Safety.
- DIN 50049-3.1 Certificate Available

Standard:

- Basic Design to ANSI B16.34
- Inspection & testing according to API 598.
- PED 97/23/EC; ISO 9001

Specifications:

- Flow bore: Full / Standard port
- Rating: 1000 WOG.
- Temperature: -20°F ~ 400°F (PTFE)
- Materials: 1.4408, CF8M
- Size range: 1/4"~2" (DN6~DN50).

PORT TYPE	1	2	3	4
T				
L				

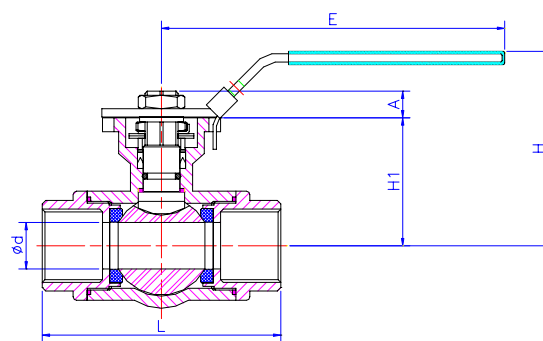
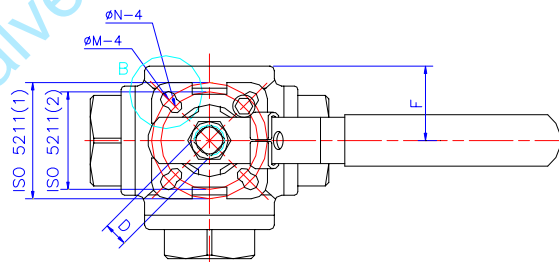

1 1/2"~2"

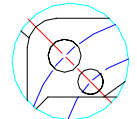

B (2:1)

1/4"~1 1/4"

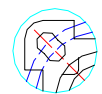

B (2:1)

Standard port Dimensions List

Size	d	L	F	H	H1	A	E	D	N	M	ISO 5211	Torque (kgf-cm)
1/4	11	75.7	38.3	64.9	36.8	8.2	132	9	6	6	F03/04	33
3/8	11	75.7	38.3	64.9	36.8	8.2	132	9	6	6	F03/04	33
1/2	12.5	75.7	38.3	64.9	36.8	8.2	132	9	6	6	F03/04	33
3/4	16	86.6	44.7	71.6	44.1	9.0	132	9	6	6	F03/04	50
1	20	103	50.8	94.3	55.1	11.5	180	11	6	7	F04/05	90
1-1/4	25	118.2	57.7	100	60.7	11.5	180	11	6	7	F04/05	170
1-1/2	32	125.8	62.7	115.7	75.2	15.1	225	14	7	9	F05/07	220
2	38	149	74.3	124.9	84.4	15.1	225	14	7	9	F05/07	380

Full port Dimensions List

Size	d	L	F	H	H1	A	E	D	N	M	ISO 5211	Torque (kgf-cm)
1/4	11	75.7	38.3	64.9	36.8	8.2	132	9	6	6	F03/04	33
3/8	11	75.7	38.3	64.9	36.8	8.2	132	9	6	6	F03/04	33
1/2	16	86.6	44.7	71.6	44.1	9.0	132	9	6	6	F03/04	50
3/4	20	103	50.8	94.3	55.1	11.5	180	11	6	7	F04/05	90
1	25	118.2	57.7	100	60.7	11.5	180	11	6	7	F04/05	170
1-1/4	32	125.8	62.7	115.7	75.2	15.1	225	14	7	9	F05/07	220
1-1/2	38	149	74.3	124.9	84.4	15.1	225	14	7	9	F05/07	380
2	50	171.2	85.6	139	94.6	18	267	17	9	11	F07/10	600

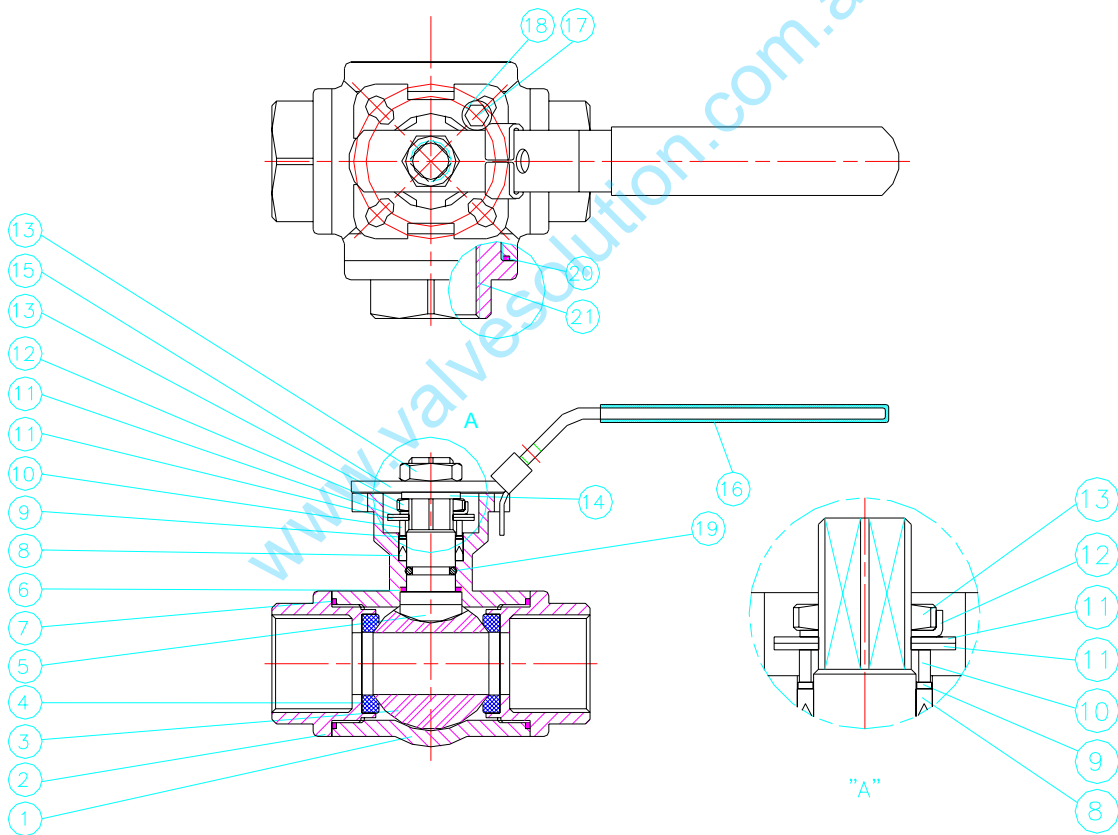

MATERIALS LIST:

NO	PART NAME	MATERIAL	NO	PART NAME	MATERIAL
1	BODY	CF8M	12	LOCK SADDLE WASHER	SS304
2	END CAP	CF8M	13	STEM NUT	SS304
3	SOLID BALL	SS 316	14	WASHER	SS304
4	BALL SEAT	PTFE	15	HANDLE	SS304
5	STEM	SS316	16	HANDLE SLEEVE	VINYL
6	THRUST WASHER	PTFE	17	BOLT	SS304
7	BODY SEAL	PTFE	18	STOPPER	SS304
8	STEM PACKING	PTFE	19	O-RING	VITON
9	THRUST WASHER	TFM1600	20	BODY SEAL	PTFE
10	GLAND	SS304	21	END CAP	CF8M
11	BELLEVILLE SPRING	SUS301	22		